

# Andromeda™ C High Mast

CERAMIC LED HIGH MAST LUMINAIRE

NICHIA HIGH POWER 90-305VAC SHOCK RESISTANT IP66 RATING 70 CRI L70 50,000 HRS 0.95 POWER FACTOR

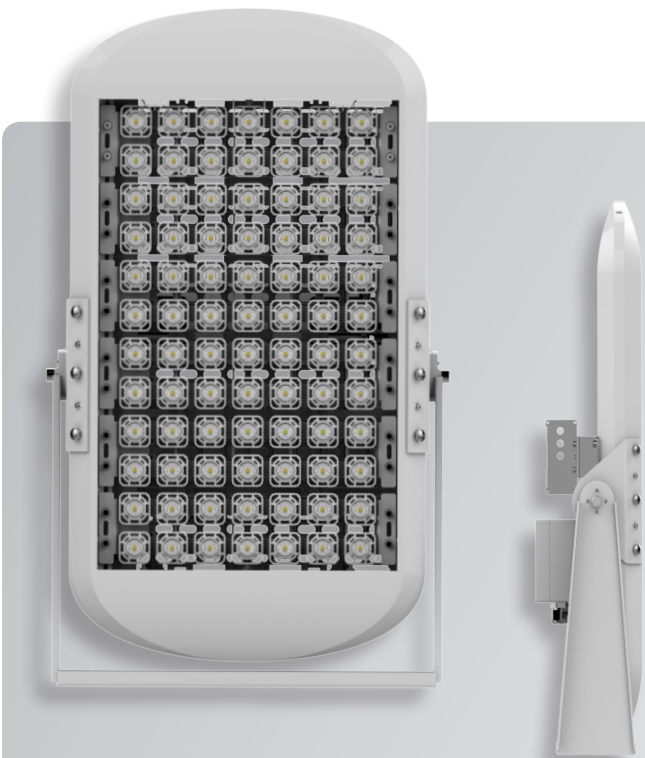

## PRODUCT INFORMATION

<b>LIGHT SOURCE</b>	Nichia High Power LED
<b>HOUSING</b>	6063 Aluminium (Marine Grade) Ceramic Diode Seat with Polycarbonate Pixel Rails
<b>BRACKET MATERIAL</b>	ST12
<b>BRACKET TYPE</b>	Trunnion Arm
<b>FRAME COLOUR</b>	Silver, White, Black
<b>MECHANICAL IMPACT RESISTANCE</b>	IK08 (Bracket & Frame Only)
<b>IP RATING</b>	IP66
<b>OPERATING TEMP</b>	-40°C to 55°C

## TECHNICAL SPECIFICATIONS

<b>INPUT VOLTAGE</b>	90-305VAC, 50/60Hz (Standard), Varying input available from 24V DC to 480V.
<b>DIMMABLE</b>	Non-dimmable standard
<b>LIFESPAN</b>	50,000 hours to L70
<b>POWER</b>	140W - 410W
<b>POWER FACTOR</b>	0.95
<b>BEAM ANGLE</b>	Distribution Ranges - Refer to lens options page
<b>LUMINOUS EFFICACY</b>	IESNA Type I,II,III, IV & V distribution
<b>CCT</b>	120 lm/W 5,000-5,500K Cool White >70 (CRI) Standard

*Additional Options - Frame options 304SS & 316SS. Dimmable with 0-10V, PWM, DALI, PE Cell or Nema 7. CCT Options - ~4000K Natural White & ~3000K Warm White.*

## SCHEMATIC OF ANDROMEDA C HMAST 360W & 410W

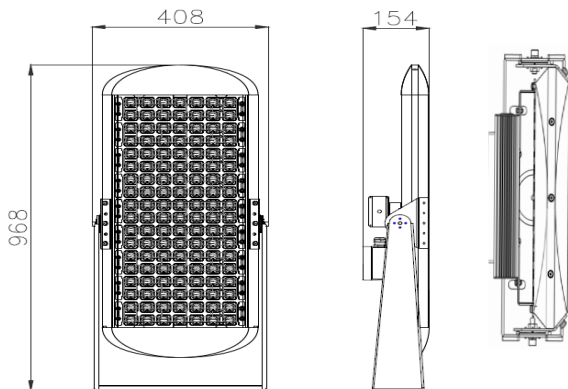

## TYPICAL APPLICATIONS

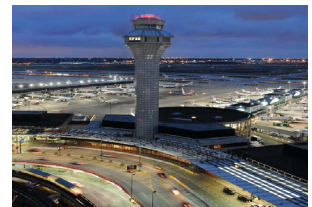

PRODUCT CODE	POWER	OUTPUT (LUMENS)	INPUT CURRENT (mA)	LENGTH (MM)	WIDTH (MM)	DEPTH (MM)	WEIGHT (KG)
Andromeda-C-HMast-140	140W	16,800	800mA	516	408	154	10.2kg
Andromeda-C-HMast-160	160W	19,200	800mA	516	408	154	10.9kg
Andromeda-C-HMast-180	180W	21,600	800mA	589	408	154	11.4kg
Andromeda-C-HMast-210	210W	25,200	800mA	589	408	154	11.7kg
Andromeda-C-HMast-220	220W	26,400	800mA	665	408	154	12.5kg
Andromeda-C-HMast-250	250W	30,000	800mA	743	408	154	13.0kg
Andromeda-C-HMast-280	280W	33,600	800mA	819	408	154	14.9kg
Andromeda-C-HMast-320	320W	38,400	800mA	892	408	154	16.5kg
Andromeda-C-HMast-360	360W	43,200	800mA	968	408	154	17.2kg
Andromeda-C-HMast-370	370W	44,400	800mA	892	408	154	18.0kg
Andromeda-C-HMast-410	410W	49,200	800mA	968	408	154	18.5kg